

ADVISOR DAY 2020

INTELLECTUAL PROPERTY | PROFIT OR POISON

Presented by

Ben Gouldson, Director

CLIFFORD GOULDSON
LAWYERS

Disclaimer

This presentation, including its contents and handouts, are provided solely for general information purposes and does not constitute legal or other professional advice. Clifford Gouldson Lawyers expressly disclaims any liability arising from the use or reliance on the information provided, the presentation, its contents and any handouts. If you require legal or other expert advice or assistance, then you should seek our help or the services of a qualified professional.

TOPICS

- A. WHAT IS INTELLECTUAL PROPERTY?
- B. PROFITING FROM IP
- C. WHAT ARE THE COSTS – THE POISON
- D. WORKSHOP CASE EXAMPLES

A. What is Intellectual Property?

1. CATEGORIES OF IP
2. REGISTRATION
3. WHERE DO RIGHTS EXIST?
4. WHO OWNS THOSE RIGHTS?

A.1. Categories of IP

TRADE MARKS



A.1. Categories of IP

PATENTS

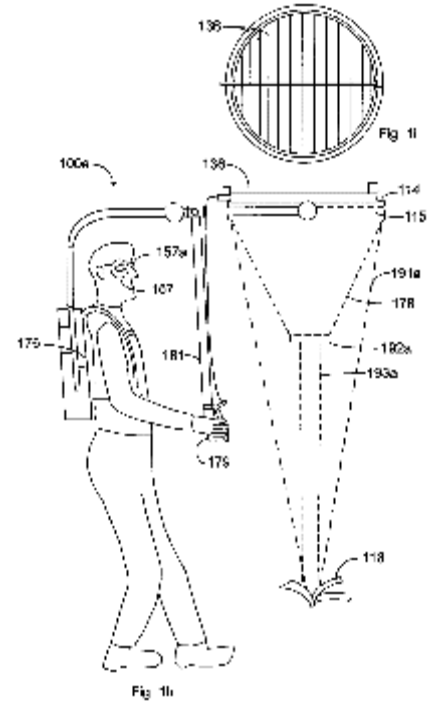
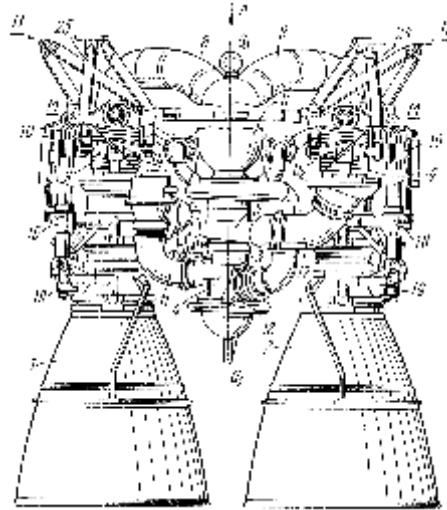

A.1. Categories of IP

DESIGNS

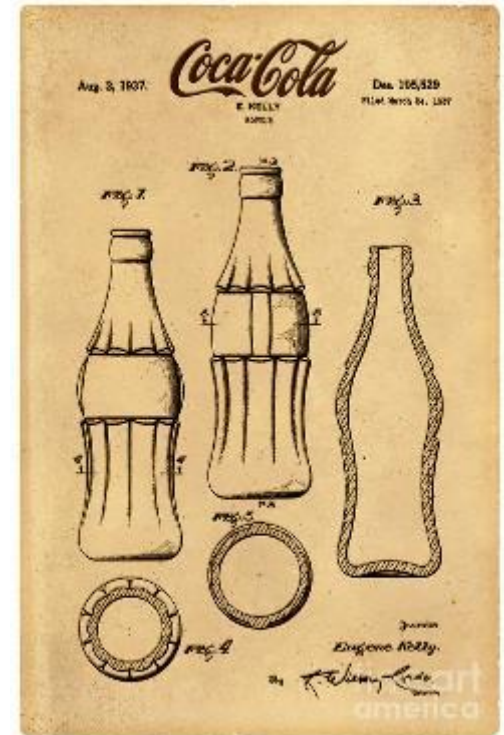
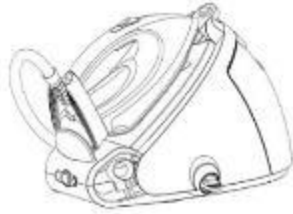

A.1. Categories of IP

PLANT BREEDER RIGHTS



A.1. Categories of IP

COPYRIGHT







A.1. Categories of IP

TRADE SECRETS

CONFIDENTIAL INFORMATION

CIRCUIT LAYOUT RIGHTS

A.2. Registration

IP SEARCH	
	Search patents Australian (AusPat) International
	Search trade marks Australian International
	Search designs Australian Design Search International
	Search plant breeder's rights PBR database



A.3. Where do those rights exist?

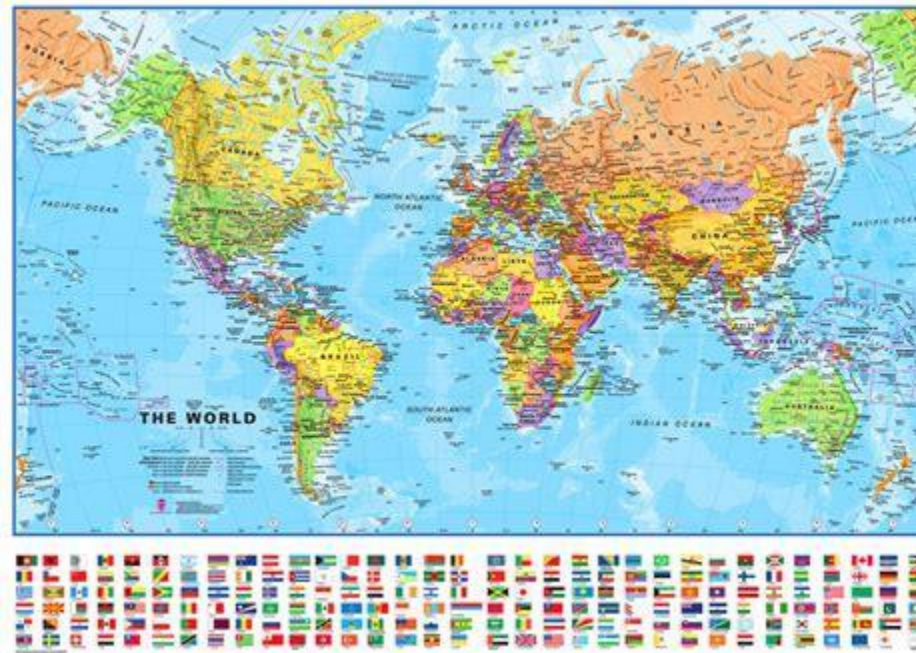

A.4. Who owns those rights?



B. Profiting from Intellectual Property?

1. IDENTIFYING IP
2. VALUING IP
3. BALANCE SHEETS AND IP
4. SELLING AND LICENSING IP

B.1. Identifying IP



B.2. Valuing IP



B.3. Balance Sheets and IP

Tesla, Inc.

Balance Sheet (10K)
02/23/2018

YE December 31.

2017

2016

Assets		
Current Assets		
Cash and cash equivalents	\$3,367,914	\$3,393,216
Restricted cash	155,323	105,519
Accounts receivable, net	515,381	499,142
Inventory	2,263,537	2,067,454
Prepaid expenses and other current assets	268,365	194,465
Total current assets	\$6,570,520	\$6,259,796
Long-Term Assets		
Operating lease vehicles, net	4,116,604	5,919,880
Solar energy systems, leased and to be leased	6,347,490	5,919,880
Property, plant and equipment, net	10,027,522	5,982,957
Intangible assets, net	361,502	376,145
Goodwill	60,237	-
MyPower customer notes receivable, net	456,652	506,302
Restricted cash, net of current portion	441,722	268,165
Other assets	273,123	216,751
Total Long-Term Assets	\$22,084,852	\$16,404,280
Total assets	\$28,655,372	\$22,664,076

B.4. Selling and Licensing IP

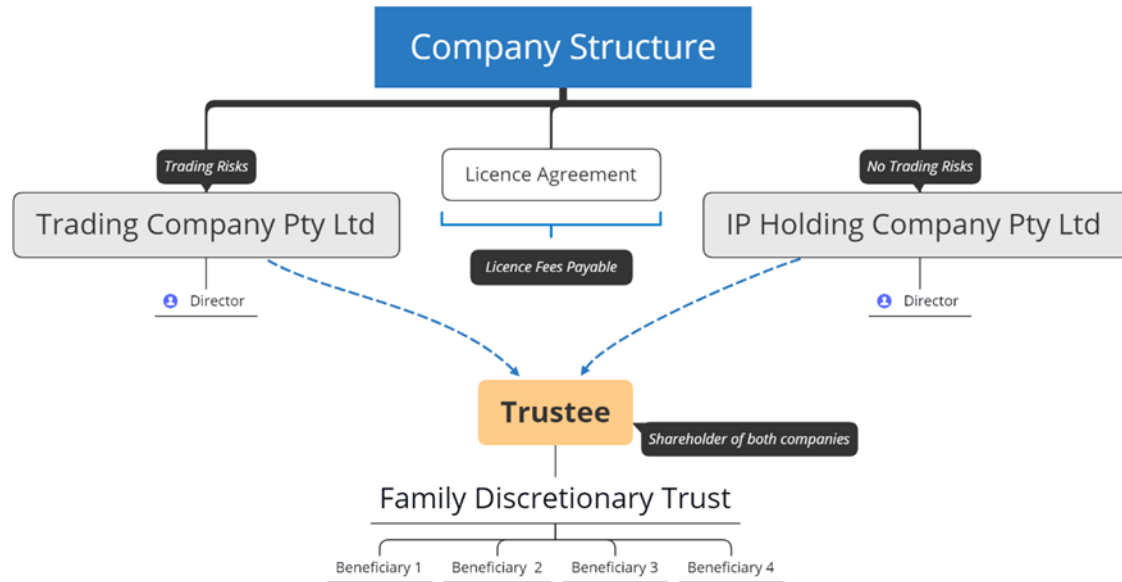

C. What are the Costs – The Poison?

1. MAINTAINING REGISTRATION
2. KEEPING A WATCH SERVICE
3. IDENTIFYING INFRINGERS
4. TAKING ACTION

D. Workshop Case Examples

1. SOFTWARE DEVELOPMENT AGREEMENT
2. BRAND PROTECTION & LICENSE AGREEMENT
3. COPYRIGHT, DESIGNS & TRADE MARK INFRINGEMENT

Workshop 1: Software Development Agreement

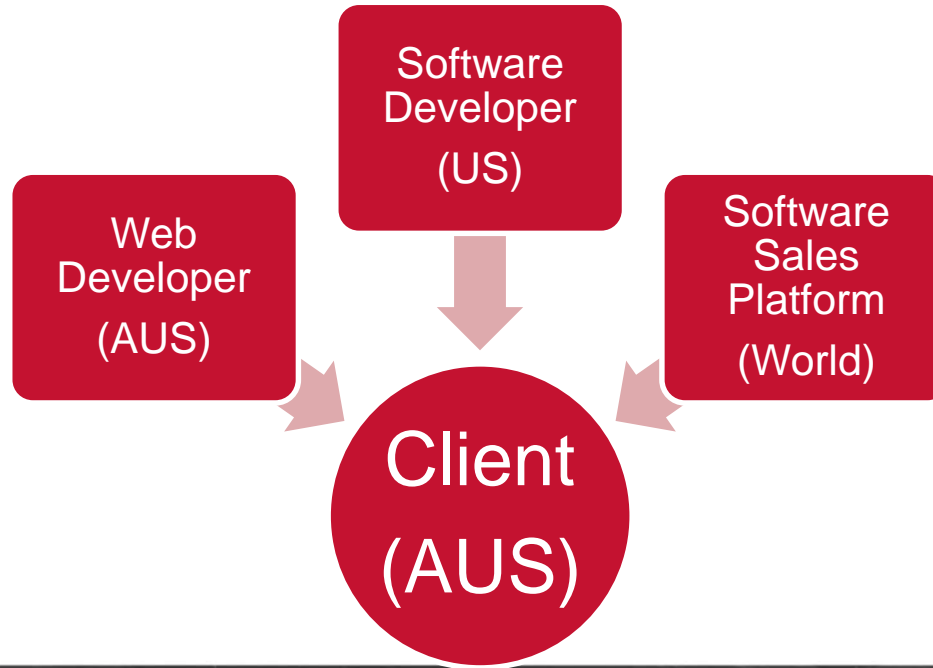

Workshop 1: Software Development Agreement

6.09 CHOICE OF LAW. THIS AGREEMENT SHALL BE CONSTRUED AND THE LEGAL RELATIONS BETWEEN THE PARTIES DETERMINED IN ACCORDANCE WITH THE LAWS OF THE STATE OF ILLINOIS, USA, WITHOUT GIVING EFFECT TO ANY CHOICE OF LAW RULES WHICH MAY DIRECT THE APPLICATION OF THE LAWS OF ANY OTHER JURISDICTION. Any legal action, including any injunctive or other equitable relief, shall be brought in a court of competent jurisdiction sitting in Cook County, Illinois.

Workshop 1: Software Development Agreement

- INADEQUATE SOFTWARE DEVELOPMENT MILESTONES
- INADEQUATE DESCRIPTIONS OF SERVICE LEVELS
- PROMISED THE WORLD
- FAKE OFFICE

Workshop 1: Software Development Agreement

- AUSTRALIA'S FIRST ANTI-ANTI SUIT INJUNCTION
- FEDERAL COURT OF AUSTRALIA
- JUDGMENT FOR \$448,837.59 PLUS INTEREST PLUS COSTS
- ENFORCEMENT IN THE US?
- PRIVATE INTERNATIONAL LAW

Workshop 2: Brand Protection & Licensing

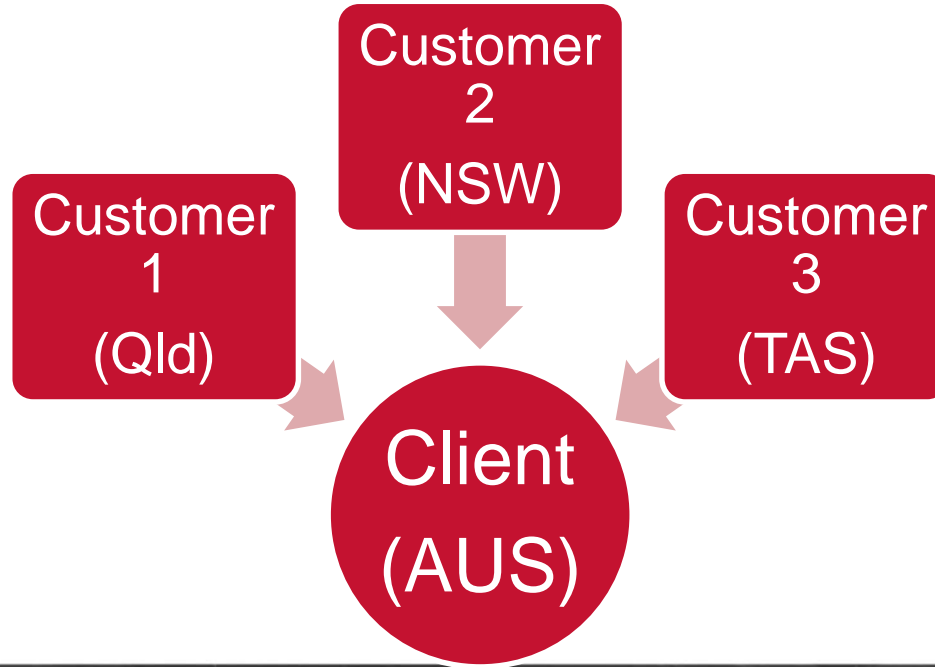

Workshop 2: Brand Protection & Licensing

- NO TRADE MARKS
- LIMITED DOCUMENTATION AROUND USE OF LOGO
- FACING LACK OF CONNECTIVITY WITH CLIENTS

Workshop 2: Brand Protection & Licensing

- REGISTERED WORD, COMPOSITE, LOGO AND SERIES MARKS
- DEVELOPED A LICENCE AGREEMENT AND TERMS OF TRADE
- BUILT EXCITEMENT AND A FEELING OF EXCLUSIVITY

What have we learned?

- A. WHAT INTELLECTUAL PROPERTY IS
- B. HOW TO PROFIT FROM IP
- C. HOW TO BE COMMERCIAL AND MANAGE IP COSTS

TOOWOOMBA OFFICE

Level 1, 610 Ruthven Street, Toowoomba Q 4350
PO Box 8208, Toowoomba South Q 4350

BRISBANE OFFICE

Level 54, 111 Eagle Street Brisbane 4000

P 07 4688 2188

F 07 4688 2199

E mail@cglaw.com.au

www.cglaw.com.au

**CLIFFORD GOULDSON
LAWYERS**

- WORKPLACE ■ LITIGATION + DISPUTE RESOLUTION ■ COMMERCIAL + PROPERTY ■ INTELLECTUAL PROPERTY
- CONSTRUCTION ■ TAX, STRUCTURES + PLANNING ■ RESOURCES

The content of this presentation does not constitute legal advice. For advice regarding your particular circumstances please contact our office.